

Wireless Liquid Level Sensor

General Description

The wireless liquid level sensor uses a solid state, continuous (multi-level) fluid level sensor for measuring levels in water, non-corrosive water based liquids and dry fluids (powders).

Features

- Detects level of water or liquid in a container.



Free basic online wireless sensor monitoring and notification system to configure sensors, view data and set alerts via SMS text and email.

Principle of Operation

The wireless liquid level sensor uses a solid-state, resistance sensitive ribbon sensor to measure the level of a liquid in a container. User customization allows you to set the frequency of sensor readings. The readings are sent to the Online Sensor Monitoring and Notification System. Stores all data in the online system where the data can be reviewed and exported as a data sheet or graph. Notifications can be set up through the online system to alert the user when set levels are reached.

Example Applications

- Monitor and track tank levels
- Monitor and track container levels
- Track non-corrosive fluid levels
- Monitor sump pit levels

And many more...

Sensor Core Spec

- Wireless Range: 250 - 300 ft. (non-line-of-sight / indoors through walls, ceilings & floors) *
- Communication: RF 900, 920, 868 and 433 MHz
- Power: Replaceable batteries (optimized for long battery life, line-power and solar (Industrial only) options are available.
- Battery Life (at 1 hour heartbeat setting): **
AA battery > 4-8 years

- * Actual range may vary depending on environment.
- ** Battery life is determined by sensor reporting frequency and other variables.

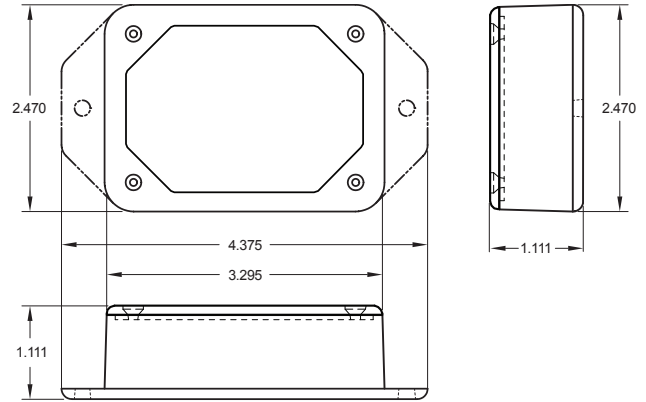

Wireless Liquid Level Sensor (AA) - Technical Specifications

Supply Voltage	2.0 - 3.6 VDC *
Current Consumption	6 μ A (accelerometer listening for vibrations) 0.7 μ A (sleep mode after measurement) 2 mA (radio idle/off mode) 2 mA (measurement mode) 25 mA (radio RX mode) 35 mA (radio TX mode)
Operating Temperature Range (Board Circuitry and Batteries)	-18°C to 55°C (0°F to 130°F) using alkaline -40°C to 60°C (-40°F to 140°F) using lithium **
Optimal Battery Temperature Range (AA)	+10°C to +50°C (+50°F to +122°F)
Ribbon Sensor Length	8 in. = 8.1" (205.74mm) 24 in. = 24.1" (612.14mm)
Ribbon Sensor Width	1.0" (25.4mm)
Ribbon Sensor Thickness	0.015" (0.381mm)
Active Sensor Length	8 in. = 8.6" (218.4mm) 24 in. = 22.6" (218.4mm)
Sensor Resolution	1/32 inch (0.794mm)
Actuation Depth	Nominal 1 inch (25.4mm)
Sensor Material	Polyethylene Terephthalate (PET)
Weight	3.7 oz.
Wireless Range	250 - 300 ft. (Through walls, ceilings and floors) Range may vary according to environmental variables.
Certifications	900 MHz product; FCC ID: ZTL- RFSC1 and IC: 9794A-RFSC1. 920 MHz product; ARIB STD-T108 R210-103733. 868 and 433 MHz product tested and found to comply with: CISPR 22:2008-09 / EN 55022:2010 - Class B and ETSI EN 300 220-2 V2.4.1 (2012-05).

* Hardware cannot withstand negative voltage. Please take care when connecting a power device.

** At temperatures above 100°C, it is possible for the board circuitry to lose programmed memory.

Power Options

Two replaceable 1.5V AA sized batteries are included with the standard model. A line-power version with battery backup is also available - allowing it to be powered by a standard 3.0 - 3.6V power supply and use the internal batteries if there is a power interruption.

Power options must be selected at time of purchase as the internal hardware of the sensor must be changed to support the selected power requirements.

Notes:

Commercial Grade Sensors

Commercial grade sensors are designed for applications in ordinary environments (normal room temperature, humidity and atmospheric pressure). Do not use these sensors under the following conditions as these factors can deteriorate the product characteristics and cause failures and burn-out.

- Corrosive gas or deoxidizing gas - chlorine gas, hydrogen sulfide gas, ammonia gas, sulfuric acid gas, nitric oxides gas, etc.)
- Volatile or flammable gas
- Dusty conditions
- Under low or high pressure
- Wet or excessively humid locations
- Places with salt water, oils chemical liquids or organic solvents
- Where there are excessively strong vibrations
- Other places where similar hazardous conditions exist

Use these products within the specified temperature range. Higher temperature may cause deterioration of the characteristics or the material quality.